



Hi-Flo™ RD Valve (Radiused Disc Ring Valve)

CPI Hi-Flo™ RD valves feature aerodynamic radiused profiled rings that control and seal process gas as it flows in and out of the compressor cylinder, providing increased efficiency and reliable operation in applications where temperatures and pressures are extreme. The durable thermoplastic radiused profile ring surface discourages the adherence of small particles of metal, sand or salt, providing improved performance over metal and non-profiled rings, which often become nicked, worn, cracked or warped. Each Hi-Flo™ RD valve is custom designed for its individual application to match specific compressor operating conditions.

DESIGN FEATURES

- Internal center bolt features a simple, reliable design that is easy to assemble
- Aerodynamic rings allow the free passage of foreign material and liquid slugs
- Secondary guidance prevents excessive lateral ring movement
- Springs are offered in chrome silicon and Hastelloy C materials
- Seats and guards are offered in Ductile Iron and 4140 alloy steel for standard valves and in 17-4 stainless steel for corrosive applications

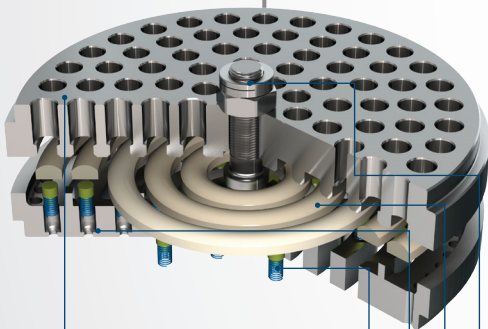

Proven Solutions for the Global Compression Industry™

Hi-Flo™ RD Valve (Radiused Disc Ring Valve)

FEATURES

- Reliable performance in the most demanding operating conditions
- Provides increased operational efficiency and reduced power consumption
- Offers improved flow and reduced pressure drop and back flow
- Easily maintained and reconditioned
- Nose diameter – 2.375 in/60 mm and up
- Capable of operating across a wide range of parameters, including:
 - temperatures up to 390°F/200°C
 - pressures up to 6000 psi/400 bar
- Delivers self-aligning performance with good conformability and effective sealing throughout changing temperatures during operating cycles
- Custom spring design for each application to optimize opening and closing time
- Available with finger and plug-type unloaders
- Suitable for:
 - both lubricated and non-lubricated compressors
 - sour gas applications
 - compressor speed up to 1800 RPM

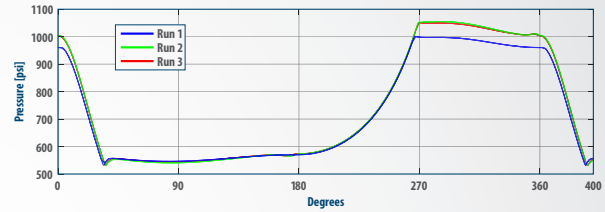
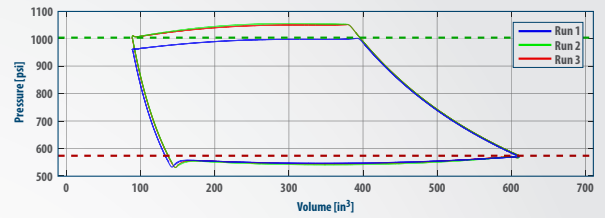

CPI provides comprehensive compressor valve performance analysis.

CPI Non-Return Valves (NRV)

CPI manufactures Non-Return Valves for air and gas compressor applications and pipelines, using the Hi-Flo™ RD valve design. NRV are used to direct flow and to manage gas conditions. NRV can be manufactured to fit customers' existing housings. Alternatively, a CPI-designed housing can be supplied.

Radiused Profile Ring Design

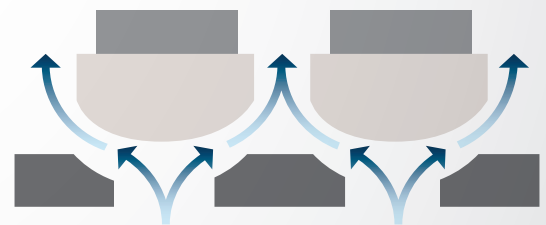

Gas flow diagram



Proven Solutions for the Global Compression Industry™